

Lesson 4: Solving for Unknown Angles Using Equations **PART III**

Classwork

Opening Exercise

The complement of an angle is four times the measurement of the angle. Find the measurement of the angle and its complement.

Example 1

Find the measurements of $\angle FAE$ and $\angle CAD$.

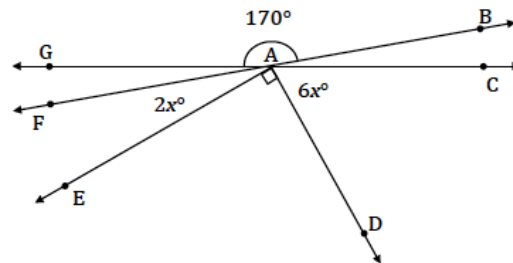

Two lines meet at a point. List the relevant angle relationship in the diagram. Set up and solve an equation to find the value of x . Find the measurement of one of the vertical angles.

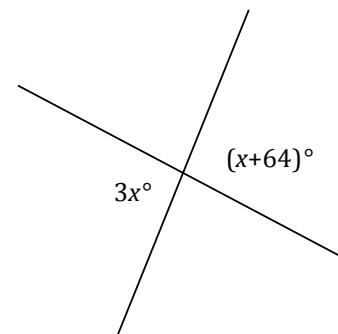

Exercise 1

Set up and solve an equation to find the value of x . List the relevant angle relationship in the diagram. Find the measurement of one of the vertical angles.

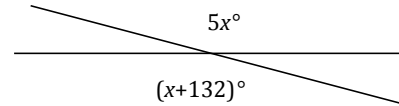

Example 2

Three lines meet at a point. List the relevant angle relationships in the diagram. Set up and solve an equation to find the value of b .

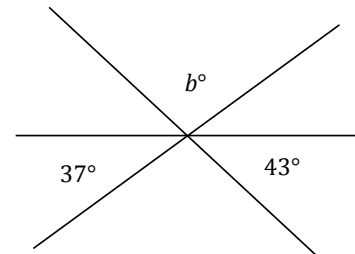

Exercise 2

Two lines meet at a point that is also the endpoint of two rays. List the relevant angle relationships in the diagram. Set up and solve an equation to find the value of b .

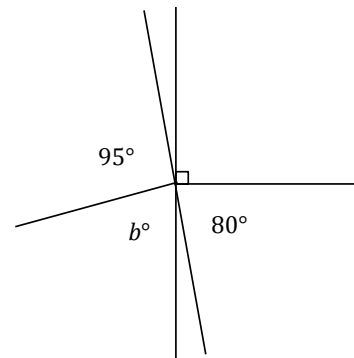

Example 3

The measurement of an angle is $\frac{2}{3}$ the measurement of its supplement. Find the measurements of the angle and its supplement.

Exercise 3

The measurement of an angle is $\frac{1}{4}$ the measurement of its complement. Find the measurements of the two complementary angles.

Example 4

Three lines meet at a point that is also the endpoint of a ray. List the relevant angle relationships in the diagram. Set up and solve an equation to find the value of z .

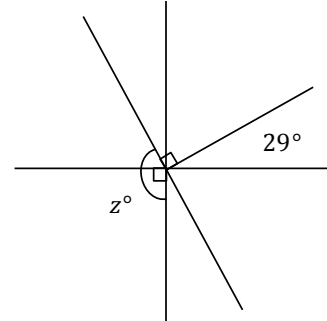

Exercise 4

Two lines meet at a point that is also the vertex of an angle. Set up and solve an equation to find the value of x . Find the measurements of $\angle GAF$ and $\angle BAC$.

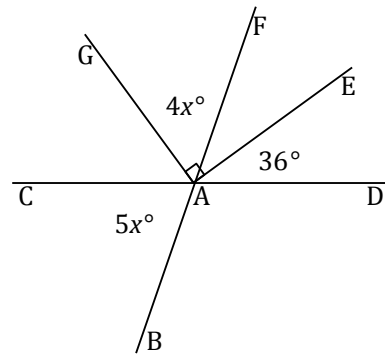

Lesson Summary

Steps to Solving for Unknown Angles

- Identify the angle relationship(s).
- Set up an equation that will yield the unknown value.
- Solve the equation for the unknown value.
- Substitute the answer to determine the measurement of the angle(s).
- Check and verify your answer by measuring the angle with a protractor.

Problem Set

1. Four rays have a common endpoint on a line. Set up and solve an equation to find the value of c .

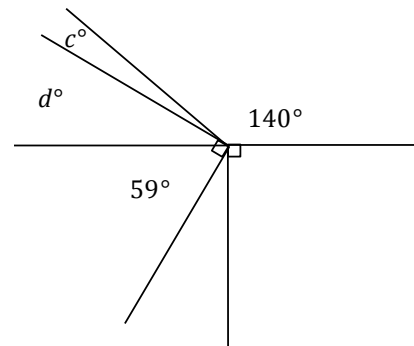

2. Lines BC and EF meet at A . Set up and solve an equation to find the value of x . Find the measurements of $\angle EAH$ and $\angle HAC$.

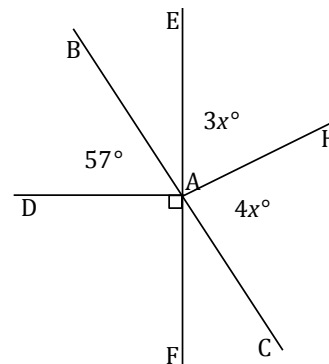

3. Five rays share a common endpoint. Set up and solve an equation to find the value of x . Find the measurements of $\angle DAG$ and $\angle GAH$.

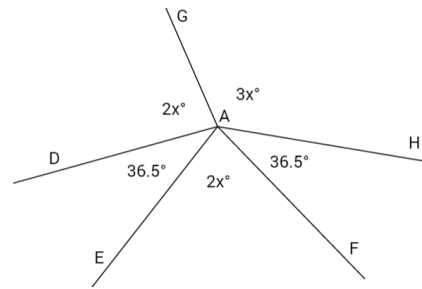

4. Four lines meet at a point which is also the endpoint of three rays. Set up and solve an equation to find the values of x and y .

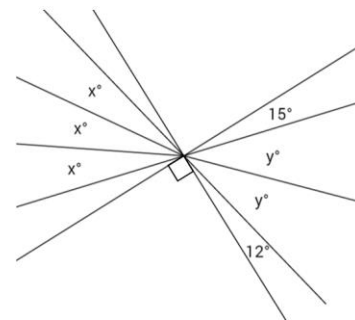

5. Two lines meet at a point that is also the vertex of a right angle. Set up and solve an equation to find the value of x . Find the measurements of $\angle CAE$ and $\angle BAG$.

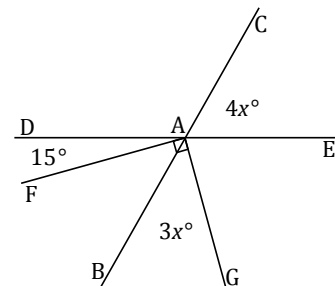

6. Five angles are at a point. The measurement of each angle is one of five consecutive, positive whole numbers.
- Determine the measurements of all five angles.
 - Compare the expressions you used for the five angles and their combined expression. Explain how they are equivalent and how they reveal different information about this situation.
7. Let x° be the measurement of an angle. The ratio of the measurement of the complement of the angle to the measurement of the supplement of the angle is 1:3. The measurement of the complement of the angle and the measurement of the supplement of the angle have a sum of 180° . Use a tape diagram to find the measurement of this angle.

8. Two lines meet at a point. Set up and solve an equation to find the value of x . Find the measurement of one of the vertical angles.

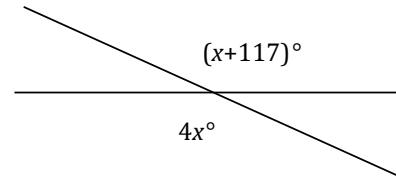

9. The difference between three times the measurement of the complement of an angle and the measurement of the supplement of that angle is 20° . What is the measurement of the angle?